

Customer No.:

CM8290-B500BA-E Camera Module

有害物质管理标准

欧盟ROHS环保指令

有害物质管理标准

30PIN DESCRIPTION

| PIN NO. | SIGNAL |
|---------|-------------|
| 1 | STROBE |
| 2 | AF_GND |
| 3 | AF_VDD_2.8V |
| 4 | ACND |
| 5 | AVDD_2.8V |
| 6 | DCND |
| 7 | SIOC |
| 8 | SIOD |
| 9 | RESET |
| 10 | NC |
| 11 | DCND |
| 12 | DCND |
| 13 | PMON |
| 14 | DCND |
| 15 | DCND |
| 16 | MDP2 |
| 17 | MDN2 |
| 18 | DCND |
| 19 | MDP |
| 20 | MCN |
| 21 | DCND |
| 22 | MDP1 |
| 23 | MDN1 |
| 24 | DCND |
| 25 | XCLK |
| 26 | DCND |
| 27 | DVDD_1.5V |
| 28 | D0VDD_1.8V |
| 29 | DCND |
| 30 | ID |

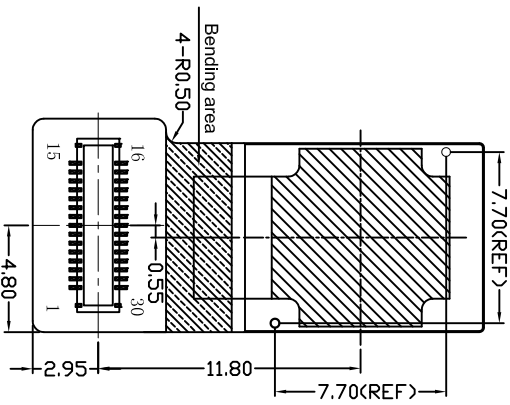
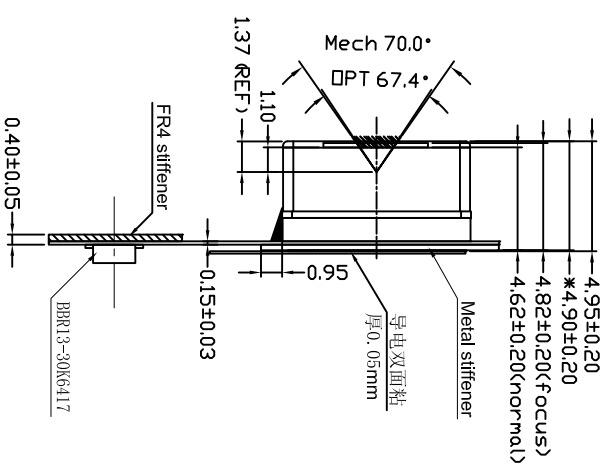
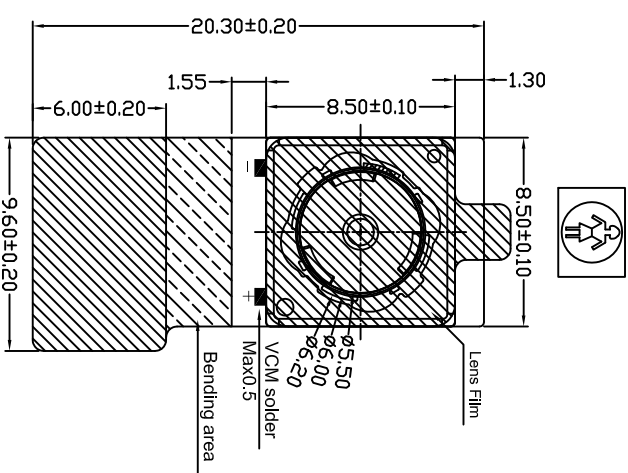

| 主要参数 (Module Specification) | |
|-----------------------------|------------------|
| 焦距 (F#) | 3.37 |
| 光圈 (F.NO) | 2.8 |
| 视场角 (View Angle) | 67.4° |
| 畸变 (Distortion) | < 1 % |
| 景深 (Focusing Range) | 10 cm ~ Infinity |
| 感光芯片 (Chip Type) | HI-542 |
| 像素 (Array Size) | 5.0M |
| 镜头类型 (Lens Size) | 1/4INCH 4P+IR |

- 备注:
1. 带*号尺寸为关键尺寸;
 2. VCM Driver为DW9712L;
 3. 马达I2C外部控制;
 4. ID接DOVDD拉高。

| Actuator Specification | |
|------------------------|---------------|
| Type | VCM Parameter |
| Control Mode | IIC |
| Supply Voltage | 2.6V~3.3 V |
| Coil Resistance | 16±2 ohm |
| Rated Current | ≤100mA |
| Lens Movement | 0.28mm(Max) |

| CUSTOMER APPROVE | | AMEND | | 手机摄像头模组 | | TRULY OPTO-ELECTRONICS LTD. | |
|------------------|------------|-------|--|-----------------------|------------------|-----------------------------|--------------|
| Mechanical | Electrical | | | TOLERANCE: DECIMAL | PRODUCT NO. | DRAW. NO. | REV |
| | | | | x ± .30 | CM8290-B500BA-E | | A |
| | | | | xx ± .20 | DWN 韦有兴 20111228 | DSN | 韦有兴 20111228 |
| | | | | ± 1/4 | change lens | APPD | 刘铁楠 20111228 |
| | | | | | CONTENT | UNIT mm | SHEET: |
| | | | | | DATE | | |
| | | | | | 20111228 | | |